

# Lombard Auto Tractor-Truck

## LIST OF PARTS

STEAM LOCOMOTIVE ENGINE

LOMBARD TRACTION ENGINE COMPANY

WATERVILLE, MAINE

## THE LOMBARD STEAM LOG HAULER AND EQUIPMENT

The Lombard Steam Log Hauler or Traction Engine, caterpillar type tread, has been in use in the United States and Canada since the year 1900 among our largest and most enterprising lumbering companies, hauling logs, both soft and hard woods, bark, cordwood, spool-bars and sawed lumber, from their yards to landing or railroad, over snow and iced roads.

These machines will operate on roads known as a wagon sled road, formerly used by horses, also on hilly roads, where it is practical to use horses, without injury to boiler.

The load that the machine can haul is governed by the road conditions, grades, number of sleds in train, and water used on roads to make ice. A machine can, if in proper hands, haul on snow-iced roads a load of 300 tons. One machine that we have a record of made 138 trips for the season with an average of 220 net tons per trip, using 7 sets of sleds per train.

These machines require four men to operate them, engineer, fireman, pilot and one to couple up sleds, assist in taking on fuel and looking after the train of sleds when on the road.

The loads are hauled on sleds in trains of from 4 to 10 sleds in each train. There should be at least three of these trains to get the full working capacity of the machine, having one train at each end of the road, and one with the machine.

Width of sleds should exceed that of machine, so that the track of sleds should be on the outside of the track of machine.

The sleds are coupled together by means of reach poles, fitted with steel ends, fitting in irons at nose of runner and irons on back of bar or bench. Sleds are coupled to machine by means of V-pole fitted with steel ends suitable for the work.

Sleds for hauling logs should have rockers equipped with some good trip stake device.

When hauling short mill logs, cordwood, spool-bars or bark, sleds can be fitted with racks suitable for the work. The wood parts for sleds are usually made by the lumbering companies at their operation. Irons for sleds are illustrated on cut No. 12, for which Lombard Traction Engine Co. hold patent rights.

The machine is steered by means of hand wheel at front of machine, and a train of gears to quadrant and sled.

A snow plow or scraper can be furnished with machine, if wanted. It is attached under the frame, and is operated from front of machine by means of hand wheel, worm and worm gear. By its use it will keep the roads level. Scraper and parts for same are illustrated on cut No. 13 of catalog.

## DESCRIPTION AND SPECIFICATION OF MACHINE

The machine is built with a horizontal type boiler. A two-cylinder horizontal engine using gear and sprocket chain for transmission of power to driving members. The water tank is filled usually from brooks or water holes near roads, using an ejector in cab with suction hose of suitable length and size. Where possible, it is better to have tanks near roads and high enough to fill machine by gravity through large hose, which will save time, these tanks to be filled by some separate device.

Length: 30 ft. over all.  
Width: 8 ft. 2 in. over all.  
Height: 9 ft. (about) over all.  
Lowest Point: 12 in. (about).  
Speed: 5 miles per hour, maximum.  
Weight: 19 tons, shipping weight uncased.  
Engine: 2-cylinder, double-acting.  
Horizontal, reversible type, 9-in. bore and 10-in. stroke.  
90-horsepower at 175 lbs. steam pressure.  
250 R. P. M. equals  $4\frac{7}{10}$  miles per hour.  
Crank pins set at 90 degrees to one another.  
Valve, balance D type, eccentric driven, link motion.  
Cylinders equipped with automatic relief valves.  
Lubricator: Hills-McCanna pump lubricator.  
Engine Control: Throttle lever in cab.  
Hand reverse lever in cab.  
Boiler: Horizontal locomotive type with forced draft.  
200lbs. working pressure.  
80 tubes  $1\frac{3}{4}$  in. diameter, 107 in. long.  
Fire Box, length inside 52 in., width inside 29 in., height above grates 41 in.  
Rocking Grates.  
Grate area, about  $10\frac{1}{2}$  sq. ft.  
Distance from top of grates to bottom of ash pan 16 in.  
Stay bolts  $1\frac{1}{8}$  in. in diameter.  
Fusible plug  $\frac{3}{4}$  in. outside type.  
Prismatic water column.  
Water fed to boiler by two Hancock injectors, type C-17 $\frac{1}{2}$ .

Boiler covered with  $1\frac{1}{2}$  in. and 2 in. asbestos lagging and sheet iron jacket

All steam pipes covered.

Water Tank: Saddle type. Capacity 425 gals.

Fuel Capacity: Coal,  $1\frac{1}{2}$  tons.

Wood,  $\frac{1}{8}$  cord, when using extension rack.

Gear Ratio: Between engine and driving member sprocket, 5.92 to 1.

Drive: Gear and sprocket chain combination.

Chain is roller thimble type.

7300 lbs. working strength.

Differential: Bevel gear type, all special nickel steel gears.

Sprockets: Special Manganese steel.

Bearings: All heavy duty bearings, bronze with compression hard grease cups.

Frame: Seven inch,  $19\frac{3}{4}$  lbs. steel channels and well braced.

Draw Bar: All steel construction with springs.

Springs: Between frame and driving members.

Driving Members: Two 6 ft. 4 in. centers. Steel construction with traction surface of 16 in. x 53 in. each.

Total traction surface, 1696 sq. in.

Each member has 29 lags and two roller chains.

Present type of links,  $\frac{5}{16}$  in. x  $1\frac{1}{2}$  in. steel, put together with  $\frac{3}{4}$  in. rivets.

Cab: Width 6 ft. 9 in.; length, 4 ft. 8 in.; height in center, 7 ft. 4 in.

Center of Driving Members to Center of Steering Members: 15 ft. 8 in.

Equipment: Full set of tools, steam hose to use in removing ice or snow from machine, 22 ft. of 2 in. heavy armored suction hose with strainer.

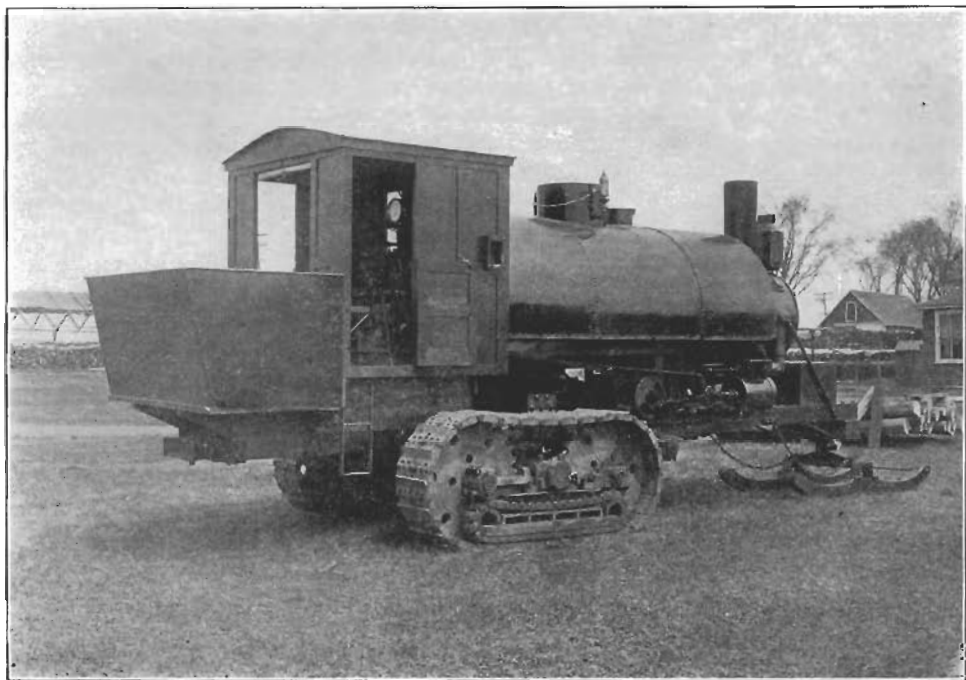

VIEW OF LOG HAULER

**WATER TANK.**—The tank is filled by means of an ejector located at rear of tank in cab. After putting hose in water hole, open cover on tank, open gate valve next to tank, then turn on steam to ejector slowly until it takes water. When through, close steam valve, close gate valve, take hose from water hole and hold in a position to drain, and turn on a little steam to blow out any water that may remain, to keep from freezing.

**BLOWER.**—There is a blower pipe and valve in cab to assist in starting fire.

**GRATES.**—There are seven grates, hitched up in two sections, which can be operated by lever in cab.

**ASH PAN.**—The ash pan is of good size and has a door, both forward and back, which is opened from the cab.

**DRIVING MEMBERS.**—Lags should not be allowed to get too slack. Lags can be taken up by loosening bolts on forward sprocket boxes, and forcing them forward by means of screw in rear of each box.

Sprocket chains can be adjusted by loosening bolts in axle box in center of driving member and forcing driving member back by means of a screw placed in driving member casting.

Roller chains can be adjusted by means of loosening forward chain guides, and forcing it ahead by means of a screw in driving member casting.

**CARE OF BOILER.**—Tubes in boiler should be brushed each day, or twice a day if in constant use. Boiler should be washed out each month. There are mud plugs through which mud can be removed and inspection made, one in front end of boiler in smoke box, one in rear head, which allows inspection of crown sheet, and one in each corner of water leg. A good deal of care should be taken in washing out boiler in the front water leg, where it gets mud from the barrel; also in water leg around fire door. Some good boiler compound should be used at regular intervals, such as, boiler compounds, graphite or kerosene.

## RUNNING HINTS

When running on the road one injector will supply enough water to boiler. For the best results in hauling good loads, don't carry too much water. When machine is standing on level road, there should not be over two gauges of water—between one and two gauges is best—for as soon as the engine begins to work, it raises water in boiler to about the third gauge. You cannot get good results with wet steam. It is a waste of water and fuel, and washes out oil in cylinder, and makes engine labor harder.

Don't be deceived when you stop, as the water level has raised when at work, and will lower when you stop. After a few runs, the engineer will readily understand these points, and guard against them without any trouble.

Don't try to fill boiler too full when approaching a down grade or hill. Keep a reasonable amount of water in boiler. When going down hill shut off steam, open cylinder drips, close drafts and open fire door.

If you wish to hold the load some with machine, draw back reverse lever toward center, and watch the action of driving members. Don't use steam, and don't allow the lag bed to stop.

These suggestions will be readily understood after a few runs.



A FLEET OF LOMBARK READY FOR WINTER USE

## SUGGESTIONS FOR RUNNING AND CARE OF MACHINES

**SHIPPING OF MACHINES.**—When machines are loaded on cars, they are blown out and contain no water, unless requested by purchaser. When shipped with water, it requires a competent man to accompany them.

**UNLOADING MACHINES.**—The machine can be unloaded either by running ahead or by backing off. Where there is a platform or wharfing by side of car, the forward end can be jacked on to wharfing and run off from car. Care should be taken when running ahead, off cars not to stop on incline for any length of time. Great care should be exercised in examination of platforms and wharfings to guard against poor construction and poor condition of same.

To unload the machine by its own power, it should be filled with water to the second gauge cock. This can be done by use of hose by connecting to blow-off valve in water leg of boiler, or by removing safety valve or whisile if there is water under pressure. Where there is not water under pressure, it can be filled through the tee by removing the safety valve and using a funnel. After having filled boiler, you are ready to build the fire, which should be a small one, to start with until the water has become warm. After starting fire, see that the combination valve on top of boiler is open to its full capacity—this valve is used only in case of emergency, and controls the steam from dome to injectors, ejector and blower—and all other valves should be closed except drips in main steampipe, exhaust pipe, cylinder drips and valve at top and bottom of water column.

**LUBRICATION.**—Fill pump lubricator with high-test steam cylinder oil, and work pump plunger until oil shows in sight feed glass in oil pipe. Put about two quarts of machine oil in differential housing through 2-in. hole in rear of housing. Use machine oil from hand can in oil tubes in main axle box, spring box housing, forward sprocket shaft, link, rocker shaft, valve motion parts, cross-head guides, parts operating oil pump and bearings operating steering members. Hard grease cups are located at oil pump, rocker stand, eccentric straps, crank shaft, bearings, connecting rods, compensating gear shafts and lag sprocket shafts.

**STARTING OF MACHINES.**—After getting sufficient steam to move machine, open drips, open throttle a little to allow the steam to blow out at drip between boiler and angle valve until all condensation has passed out, close throttle, and open angle valves in live steam pipe; open throttle a little, allowing steam to pass to cylinders; also move reverse lever back and forward until all water has passed. After finishing these operations, you are ready to move machine from cars. These same instructions will apply in cases such as machines standing for any length of time, or over night in cold weather.

**INJECTORS.**—Each machine is provided with two injectors, one on each side, within easy reach of engineer and fireman. In operating them, first open corner valve where water enters boiler, next open the steam cock in suction pipe, then open angle steam valve above injector, pull back lever operating injector a little until you get a good stream of water, continue moving lever until it is wide open, which should be forcing water in boiler. Valve below lever is to regulate amount of water thrown.

If you wish to heat water in tank through injector, close corner valve next to boiler, open steam cock in suction pipe, draw back lever on injector to its full travel, open angle valve above to allow as much steam to pass as is necessary. There is a strainer in suction pipe below injector. By taking off cap, the perforated metal can be removed and pipe washed out.

**OIL PUMP OR LUBRICATOR.**—The pump is operated from rocker shaft, and runs only when engines are in motion. As there are no steam connections, and it is open to atmosphere, it can be filled at any time. The amount of oil used can be regulated by moving connections on levers, also by screwing the nuts on plunger nearer together, or apart as the case may require.

## INDEX

CUT No. 1	ENGINE PARTS
CUT No. 2	ENGINE PARTS
CUT No. 3	ENGINE PARTS
CUT No. 4	RUNNER OR DRIVING MEMBERS
CUT No. 5	DIFFERENTIAL GEAR AND FRAME
CUT No. 6	FRAME FOR CHASSIS
CUT No. 7	STEERING GEAR AND FRONT OF BOILER ACCESSORIES.
CUT No. 8	BOILER ACCESSORIES
CUT No. 9	BOILER ACCESSORIES AND TRIMMINGS
CUT No. 10	CAB PARTS, HOSE AND HEADLIGHTS
CUT No. 11	TOOLS AND PACKING
CUT No. 12	LOGGING SLED PARTS
CUT No. 13	SNOW PLOW OR SCRAPER PARTS



CUT No. 1—ENGINE PARTS

- 1-B Guide Support to Engine Bed (New Style)
- 1-L Engine Bed on Left Side of Steamer
- 1-R Engine Bed on Right Side of Steamer
- 2 Crank Shaft Box
- 205 Brass Bearing for Crank Shaft Box
- 91 Stud, Crank Shaft Box to Engine Bed
- 92 Stud, Crank Shaft Box to Cap
- 3 Crank Shaft, complete
- 90 Spreader for Engine Beds
- 93 Forward End Cylinder Housing
- 94 Rear End Cylinder Housing
- 95-L Steam Chest Housing, Left
- 95-R Steam Chest Housing, Right
- 96 Cylinder Cock Shaft Box

CUT NO. 1

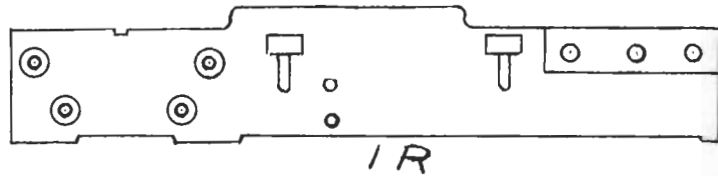
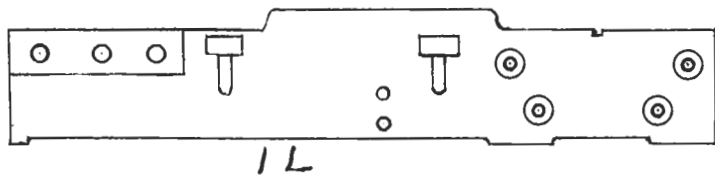
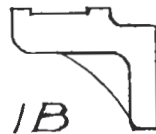
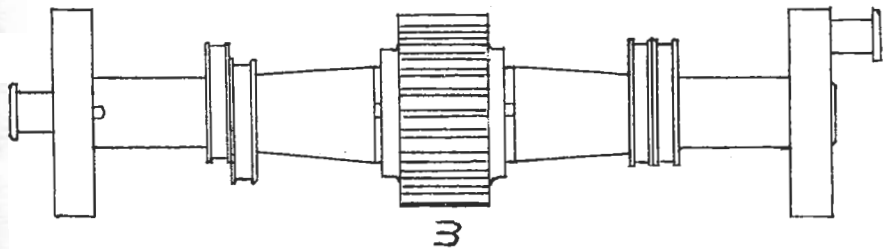
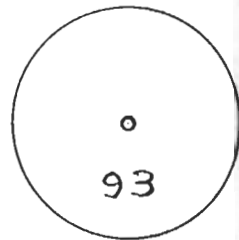
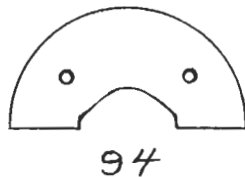
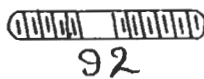
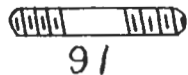
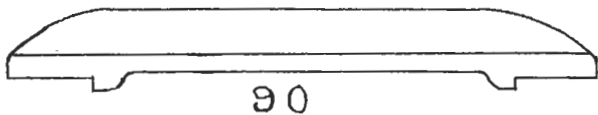
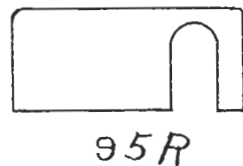
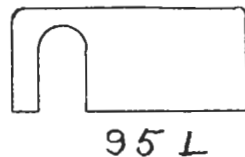
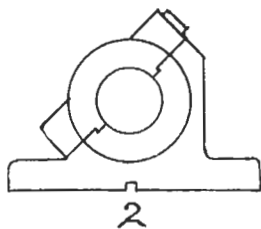

CUT No. 2.—ENGINE PARTS.

56	Nipple for No. 52	211	Lock Nut for No. 210
57	Crank Shaft alone	55	Brass Body to Grease Cup No. 220
58	Pin Wheel with Pin	220	Brass Grease Cup, complete for Connecting Rod
59	Eccentric	305	Grease Plug for Cup No. 220
60	Pin for Pin Wheel	306	Lock Nut for Cup Plug No. 305
61	Pinion Gear, 23 teeth	307	Studs for Rocker Shaft Box to Engine Bed.
300	Eccentric Set Screw	308	Studs for Standard Box No. 7 to Engine Bed
301	Button for Locking Set Screw No. 300	309	Long Drip Cock Rod
302	Key for Shaft No. 61	310	Stud for Link, connecting Nos. 25 and 26
303	Key for Eccentric No. 59	314	Reach Rod from Reverse Lever to No. 50
304	Key for Pin Wheel No. 58	315	Studs for Cylinder Head Gland No. 42
205	Brass Bearing for Crank Shaft Box	316	Studs for Steam Chest Gland No. 35
311-L	Two-inch Valve Housing for Live Steam Pipe, Left	317	Piston alone
311-R	Two-inch Valve Housing for Live Steam Pipe, Right	318	Piston Rod alone
312	Housing for 2-in. Live Steam Pipe	321	Bolt for Eccentric Strap No. 23
313	Split Ring for Valve and Elbow Housing	322	Nut for Front End of Piston No. 318
319	Long Bolt for Crank Shaft Box	323	Back half Eccentric Strap.
320	Short Bolt for Crank Shaft Box	324	Stud for Steam Chest to Cylinder
210	Grease Plug for Crank Shaft Box	325	Stud for Cylinder Head to Cylinder

CUT NO. 2

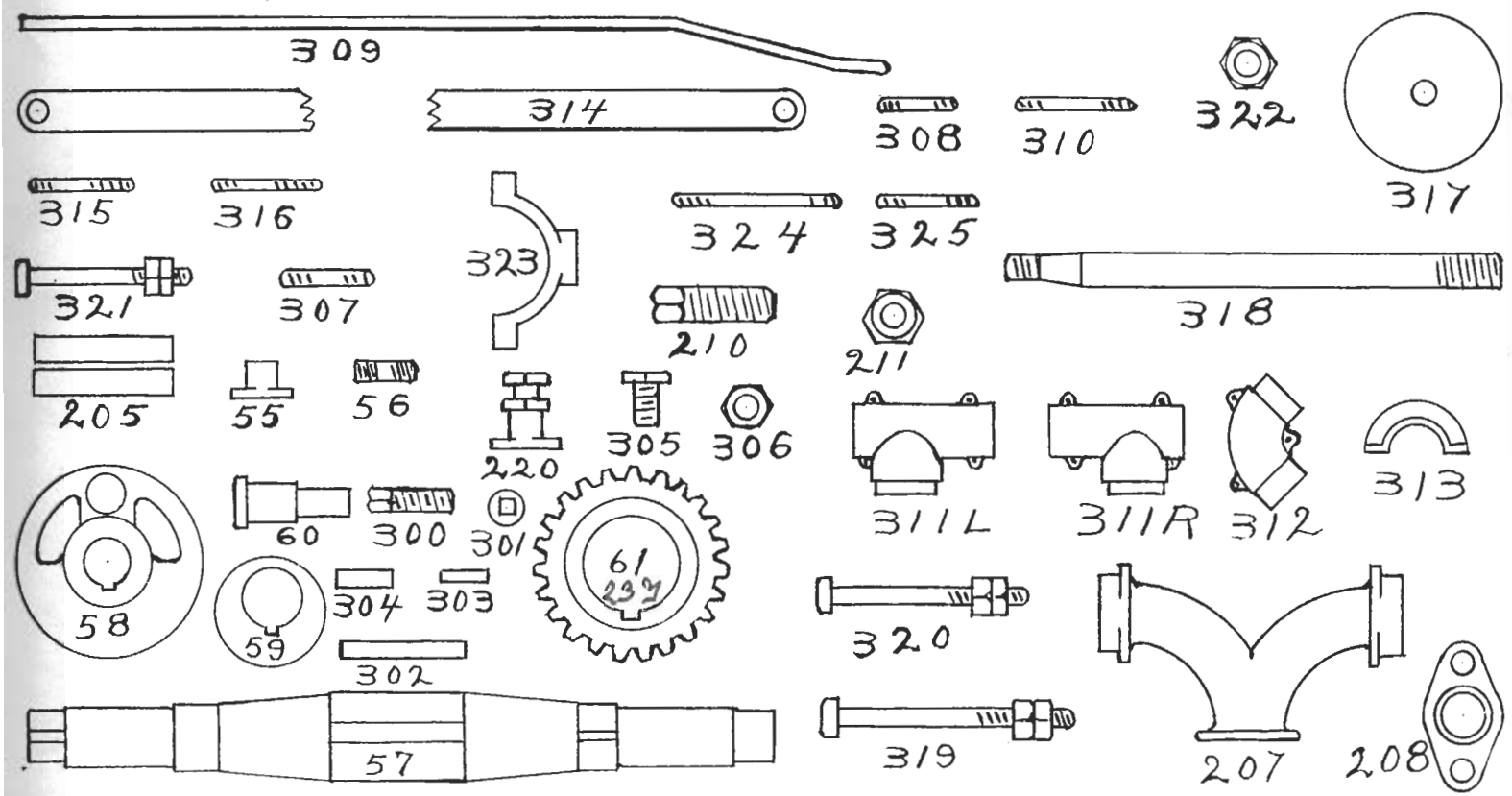

### CUT No. 3—ENGINE PARTS

4	Cylinder	31	Special Nut for Valve Stem
5	Steam Chest	32	Stud for Valve Stem
6	Steam Chest Cover	33	Stud for Link Block
7	Standard for Lifter Shaft	34	Link Hanger
8	Connecting Rod Complete	35	Gland for Valve Stem
9	Rod	36	Cross Head Pin
10	Strap for Cross Head End	37	Slide Valve
11	Strap for Crank End	38	Long Packing Strip
12	Key $\frac{7}{16}$ or $\frac{1}{2}$ in. for Cross Head End	38-A	Set of Springs (16 springs)
13	Gib $\frac{7}{16}$ or $\frac{1}{2}$ in. for Cross Head End	39	Short Packing Strip
14	Box for Crank End	40	Lifter Arm
15	Key $\frac{7}{16}$ or $\frac{1}{2}$ in. for Crank Head End	41	Nut for Piston Rod, Cross Head End
16	Gib $\frac{7}{16}$ or $\frac{1}{2}$ in. for Crank Head End	42	Gland for Piston Rod
17	Box for Cross Head End	43	Piston and Rod Complete
18	Cross Head Guide	44	Short Drip Cock Lever
19	Rocker Shaft Box	45	Rod for Drip Cock Lever
20	Collar for Lifter Shaft $1\frac{1}{16}$ in.	46	Long Drip Cock Lever
21	Cross Head Gib	47	Piston Ring
22	Eccentric Rod	48	Cylinder Head, Crank End
23	Eccentric Strap	49	Cylinder Head, Head End
24	Stud for Eccentric Rod	50	Reach Rod Lever on Lifter Shaft
25	Link	51	Valve to Cylinder Cock
26	Strap for Link	52	Brass Cylinder Cock
27	Link Block	53	Lifter Shaft
28	Distance Ring for Link	54	Coupling Bolt for Cylinder
29	Connection for Valve Stem	103	Cross Head
29-A	Connection for Valve Stem (New Style)	104	Rocker Shaft
30	Valve Stem	106	Cross Head Cover

CUT NO. 3

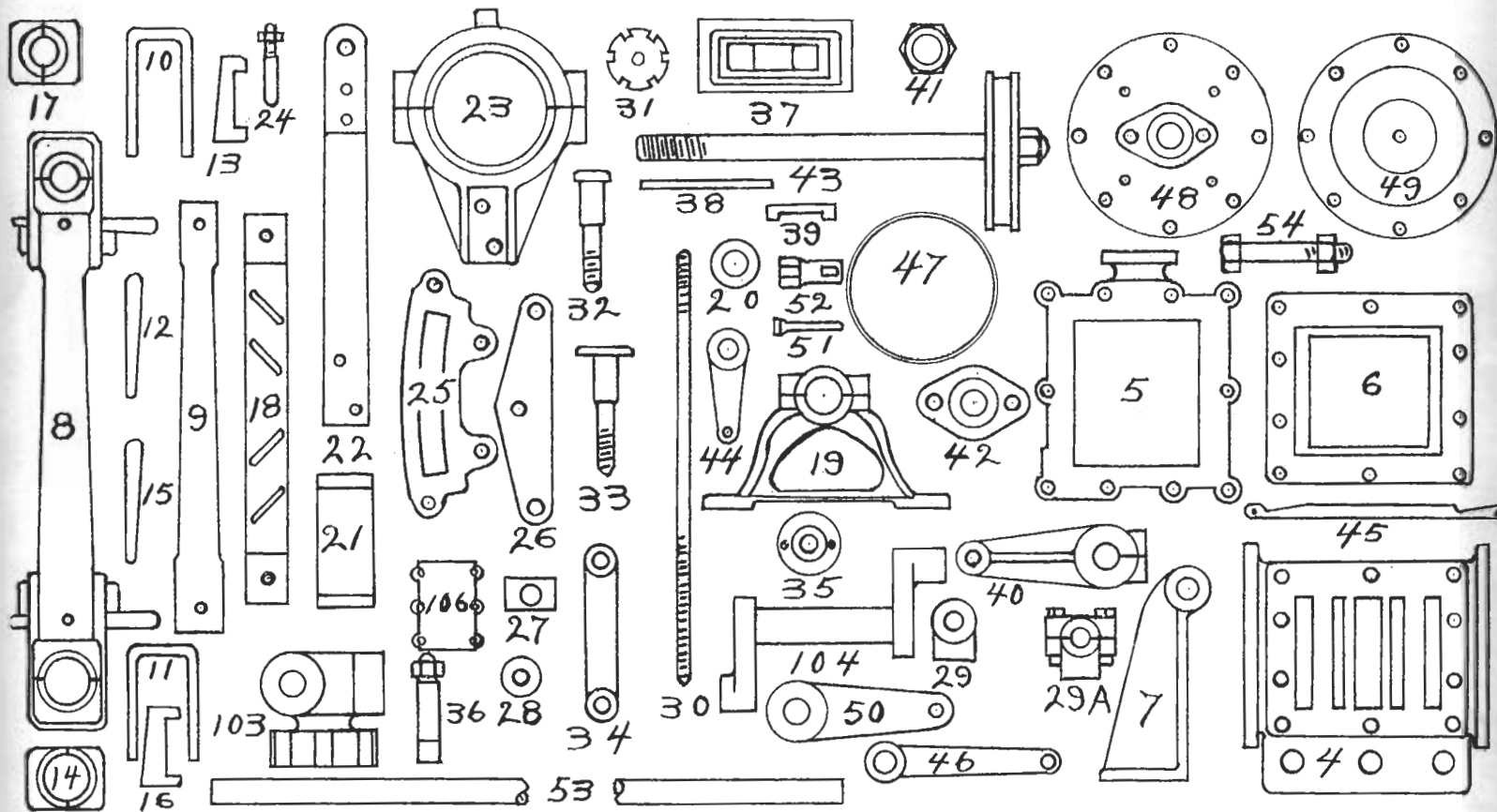

CUT No. 4--RUNNER OR DRIVING MEMBER PARTS.

62	Runner Casting	76	Forward Lag Sprocket
63	Axle Box	79	Forward Sprocket Shaft
64	Cap to Runner	7679	Assembly of Nos. 76 and 79
65	Forward Box, Left	85	Adjusting Screw for Axle Box
66	Forward Box, Right	86	Adjusting Screw for Forward Sprocket Box
67	Return Chain Guide, Rear Left (Substituted by No. 69)	206	Inside Bearing for Sprocket Shaft No. 80 (Brass)
68	Return Chain Guide, Rear Right (Substituted by No. 70)	210	Grease Plug in Runner Box
69	Return Chain Guide, Forward Right	211	Lock Nut for No. 210
70	Return Chain Guide, Forward Left	348	Inside Bearing for Sprocket Shaft No. 80 (Babbitt)
71	Shoe for Roller Chain	349	Outside Bearing for Sprocket Shaft No. 80 (Babbitt)
72	Roller Chain Complete (41 rolls)	351	1-inch Stud for Axle Box No. 63
73	Link for Roller Chain	352	$\frac{7}{8}$ -inch Stud for Forward Sprocket Shaft Box, Nos. 65 and 66
74	Roll for Roller Chain	343	Inside Strap for Roller Chain Circle
75	Pin for Roller Chain	344	Outside Strap for Roller Chain Circle
81	Lag, Steel Casting	345	Stud for Roller Chain Circle
81-M	Lag, Manganese Steel	346	Adjusting Screw for Roller Chain Circle
82	Lag Pin	347	Steel Approach to Roller Chain Circle
82-M	Lag Pin, Manganese Steel	435	Driving Chain Complete (61 links)
89	Lag Pin Roll	336	$\frac{7}{8}$ -inch Pins for Chain No. 435 (plain)
77	Rear Lag Sprocket <i>15 Lags</i>	337	$\frac{7}{8}$ -inch Pins for Chain No. 435 (with Cotters)
78	Driving Chain Sprocket, Rear - <i>22 teeth</i>	338	Side Strap for Chain No. 435
80	Rear Sprocket Shaft	339	Rolls for Chain No. 435
350	Key for Shaft No. 80	340	Bushing for Chain No. 435
7780	Assembly of Nos. 77, 78, 80 and 350	340-A	Bushing for Chain No. 435 (New Style)
		354	Link for Chain No. 435

CUT NO. 4

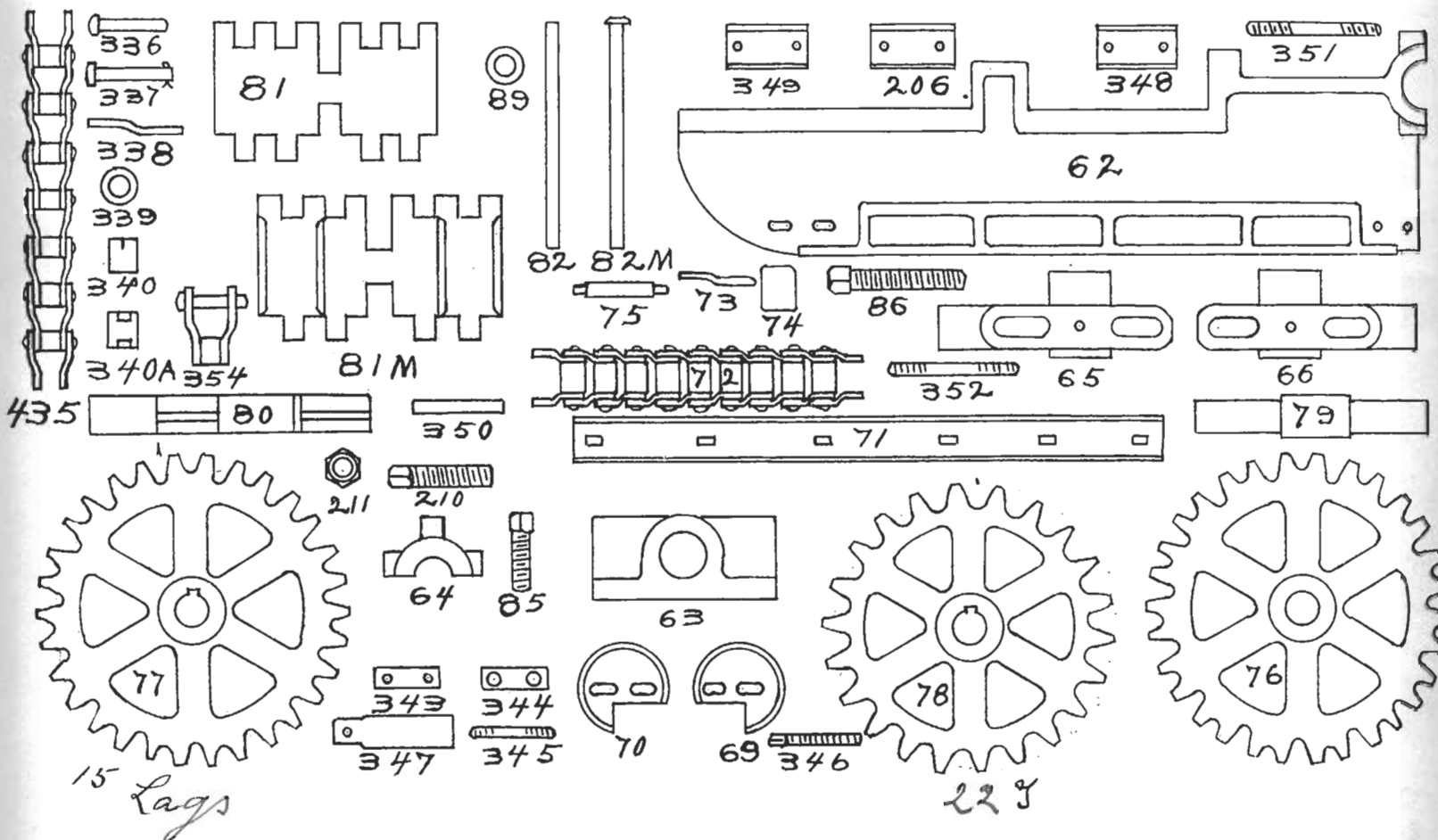



CUT No. 5—DIFFERENTIAL GEAR AND FRAME

125-A	Compensating Gear Shaft	426	Inside Cap for Compensating Boxes
126	Spur Gear, 56 Teeth, for Differential Gear	427	Outside Cap for Compensating Boxes
127	Spider for Compensating Gear	210	Grease Plug, used in Compensating Boxes Nos. 426 and 427
127-A	Bushing for Compensating Gear Spider	211	Lock Nut for No. 210
133	Driving Chain Sprocket <i>9 Teeth</i>	428	Brass Thrust Collar for Compensating Boxes
136	Bevel Gear, 36 Teeth, for Differential Gear	429	Cast Iron Thrust Collar for Compensating Boxes
139	Pin for Bevel Pinion in Compensating Gear	428-A	Brass Bi-part Thrust Collar for Compensating Boxes
141	Brass Bushing for Bevel Pinion No. 142	326	Front Bearing for Compensating Boxes (Babbitt)
142	Bevel Pinion, 16 Teeth, for Differential Gear, including No. 141 Bushing	327	Rear Bearing for Compensating Boxes (Babbitt)
143	Coupling Bolt for Compensating Gear Spider	328	Rear Bearing for Compensating Boxes (Brass)
180	Gear Pan, Lower Half	329	Stud for Connecting Compensating Boxes to Engine Bed, Front
212	Gear Pan, Upper Half	330	Stud for Connecting Compensating Boxes to Engine Bed, Rear
212-A	Top Half No. 212	341, 125-A, 136, 133, 428 and 429.	Compensating Gear Shaft, Assembled.
213	Gear Pan Support	342	Key for Shaft No. 125-A
424	Short Steel Compensating Gear Frame		
425	Short Steel Compensating Gear Frame, complete. (Not illustrated.)		

CUT NO. 5

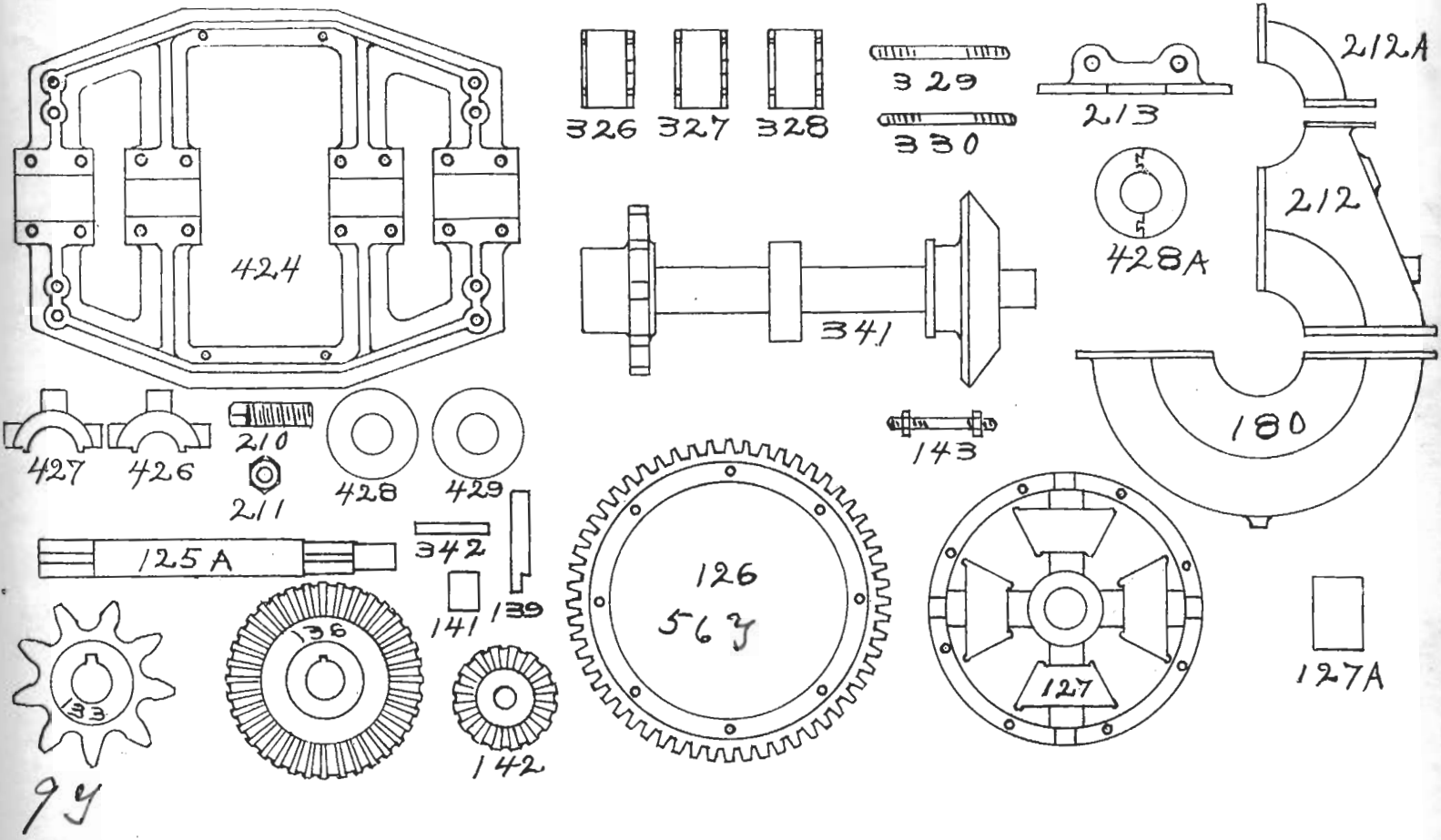

CUT No. 6--FRAME OR CHASSIS

101	Draw Bar	140	Guide for Spring.
109	Draw Bar Pin	176	Boiler Support Front (fits either side)
113	Top Iron to Draw Bar	176-L	Rear Left Boiler Support
114	Bottom Iron to Draw Bar	176-R	Rear Right Boiler Support
115	Compression Spring for Draw Bar	182-R	Right Hand Channel
117	Draw Bar Housing	183-L	Left Hand Channel
121	Clavice for Draw Bar	187	Front Brace Rod
128	Spring Box Housing	188-L	Rear Left Brace Rod
129	Spring Hanger	188-R	Rear Right Brace Rod
130	Plate for Spring Box Housing	190	Bed Stay from Boiler to Engine Bed
131	Distance Ring for Axle Shaft	191	Studs for Bolting No. 190 to Boiler
132	Spring	198	Brace Draw Bar to Channel
132-A	Small Spring for inside of No. 132	265	Front Underside Brace Rod
134	Main Axle, $4\frac{7}{16}$ or $4\frac{15}{16}$ in.	266	Brace under Spring Box Housing to Channel
135	Clamp Collar for Main Axle	267	Cross Brace between Channel, Front End
137	Spring Box, $4\frac{7}{16}$ or $4\frac{15}{16}$ in.		

CUT NO. 6

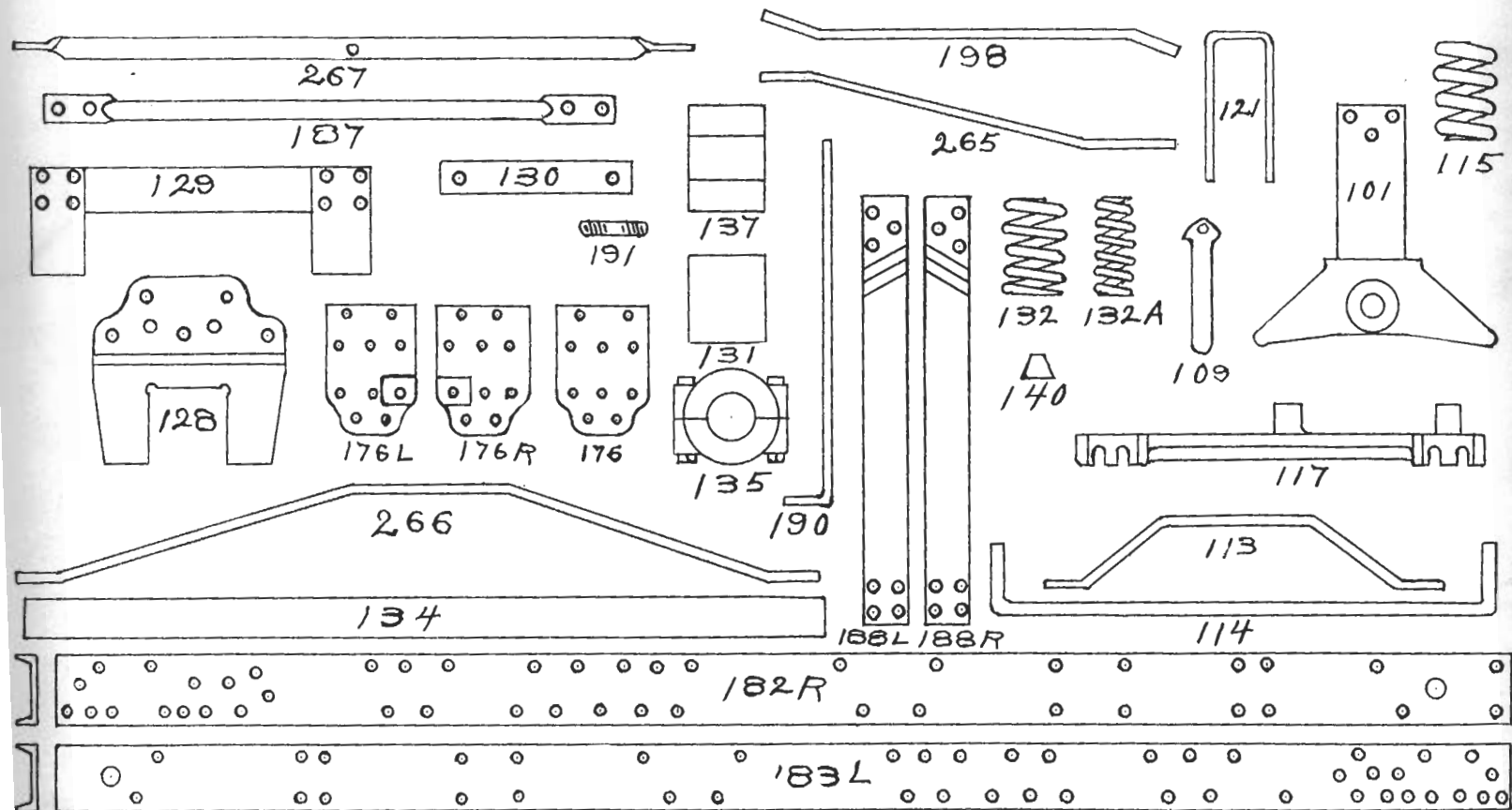

CUT No. 7—STEERING GEAR AND FRONT OF BOILER ACCESSORIES

97	Hand Wheel for Steering Gear	174	Boiler Front
102	Pinion on Hand Wheel Shaft	175	Boiler Front Door
105	Shaft for Quadrant Pinion	199	Protecting Plate for Boiler Front Door
111	Collar for Quadrant Shaft	200	Eye Bolt for Boiler Front
112	Pinion for Quadrant Shaft	361	Boiler Front Door Button
116	Gear for Steering Gear	362	$\frac{5}{8}$ -inch Stud for Boiler Front
118	Quadrant	201	Bracket Headlight
119	Main Casting for Steering Gear	202	Forward Sled Runner Stand
119-A	Box to Main Casting for Steering Gear	203	Stock to Forward Axle
177	Steering Hand Wheel Shaft	209	Forward Axle
178	Quadrant Shaft	270	Wood Runner
179	Pin for Quadrant	271	5-inch Shoe Runner
145	Hand Hole Cover	272	2-inch Keel Shoe for Runner
146	Hand Hole Ring	273	Check Chains for Sled
148	Ash Hole Ring	274	Spreader Rod for Steering Sled
152	Ash Hole Cover	275	$\frac{3}{4}$ -inch Yoke for Axle No. 209
171	Boiler Cradle	276	Wood Breast Beam

CUT NO. 7

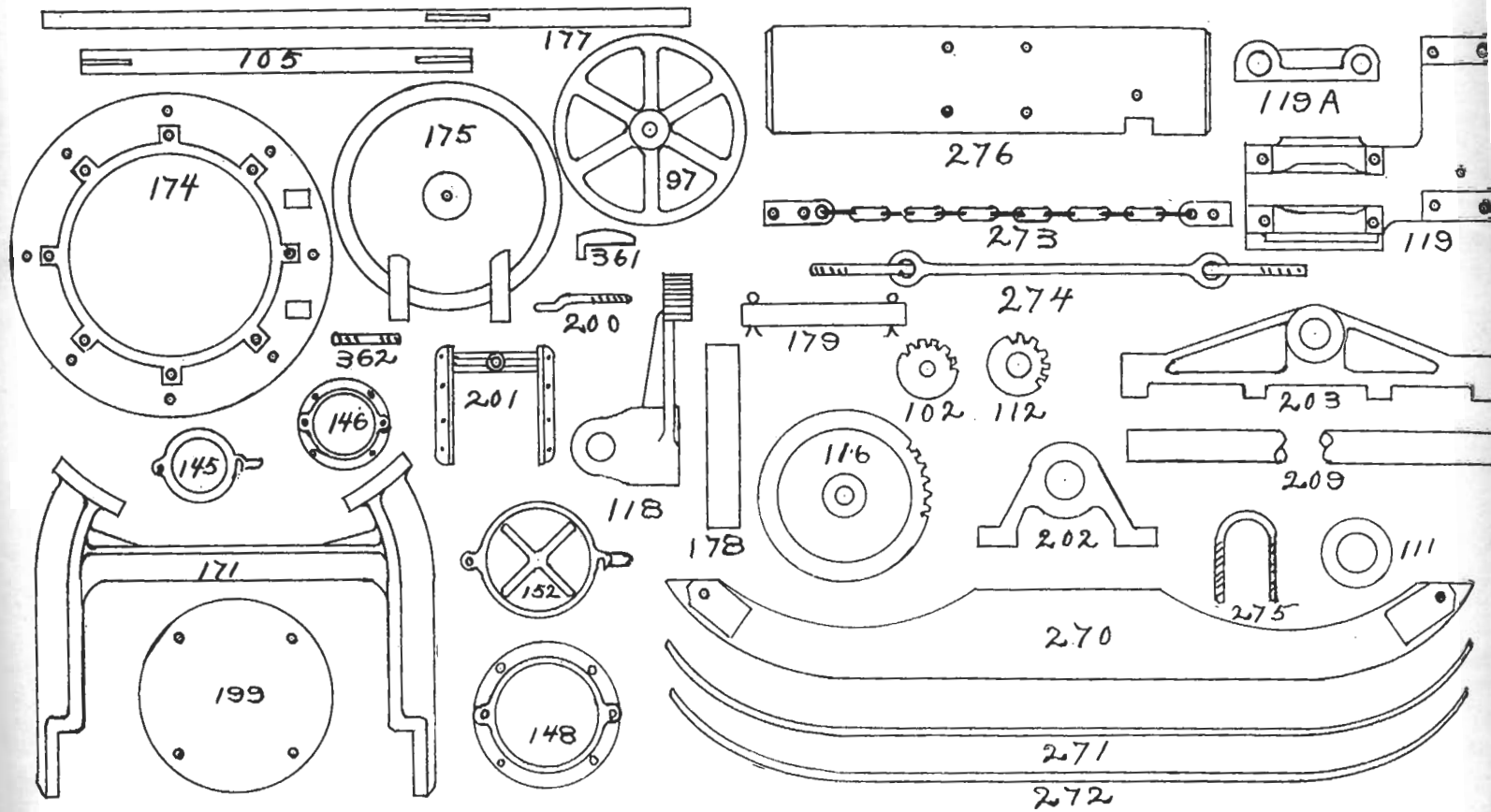

CUT No. 8—BOILER ACCESSORIES

144	Grate Hanger	196	Pin for Throttle Lever, $\frac{3}{8}$ in.
147	Arc for Reverse Lever	197	Pin for Link, $\frac{1}{2}$ in.
149	Throttle Lever Complete, assembled	204	End Grate
150	Arc for Throttle Lever	214	Exhaust Tip for Coal
151	Link for Throttle Valves	215	Exhaust Tip for Wood
153	Smoke Stack Collar	216	Floor Plate
154	Ash Pan Door Frame	217	Shaker Arm
155	Tank Cover	224	Bell Crank for Damper Door
155 $\frac{1}{2}$	Hinge to Tank Cover	247	Latch for Reverse Lever
156	Live Steam Pipe Flange	248	Rod from Latch to Grip
158	Throttle Valve Housing	248-A	Rod for Reverse Lever Latch
159	Stuffing Gland for Throttle Housing	249	Latch for Throttle Lever
160	Stuffing Box for Throttle Valve	250	Ash Pan, complete
161	Throttle Valve Flange	251	Ash Pan, sheet iron, large
163	Housing for Reverse Lever Latch	252	Ash Pan, sheet iron, small
164	Stud for Reverse Lever Latch	253	Angle Iron for Damper Door
165	Pin, $\frac{3}{8}$ in. for No. 169	254	Long Reach Rod for Damper Door
166	Brass Union, female end	255	Short Reach Rod for Damper Door
167	Throttle Valve	256	Stud for Bell Crank No. 224
168	Reverse Lever	257	Hand Rod from Bell Crank to Floor
169	Bell Crank Lever to Throttle Valve	258	Inside Connecting Rod for Grates, Long
170	Ash Pan Door	259	Inside Connecting Rod for Grates, Short
172	Live Steam Pipe Casting	260	Outside Connecting Rod for Grates, Long
173	Rocking Grate for Coal	261	Outside Connecting Rod for Grates, Short
173-A	Rocking Grate for Wood (Not illustrated)	262	Handle for Shaking Grates
181	Brass Union, male end, for Pipe Flange	297	Tubes for Boiler, $1\frac{3}{4}$ in. x 107 in.
184	Support for $2\frac{1}{2}$ -in. Pipe	356	$\frac{3}{8}$ -inch Stud for Reverse Lever Arc, Long
185	Support for 1-in. pipe	357	Exhaust Nozzle, Long
186	Stud for Pipe Supports	358	Smoke Stack
192	Short Throttle Valve Rod	359	$\frac{3}{8}$ -inch Stud for Reverse Lever Arc, Short
193	Clamp for Bell Crank Lever	360	Stud for Throttle Valve Gland
194	Connection for Long Throttle Valve Rod	407	Support for $1\frac{1}{4}$ -in. Injector Pipe
195	Reverse Lever Grip	409	Copper Ferrules for Boiler Tubes
		413	Throttle Valve Rod between Nos. 169 and 149

CUT NO. 8

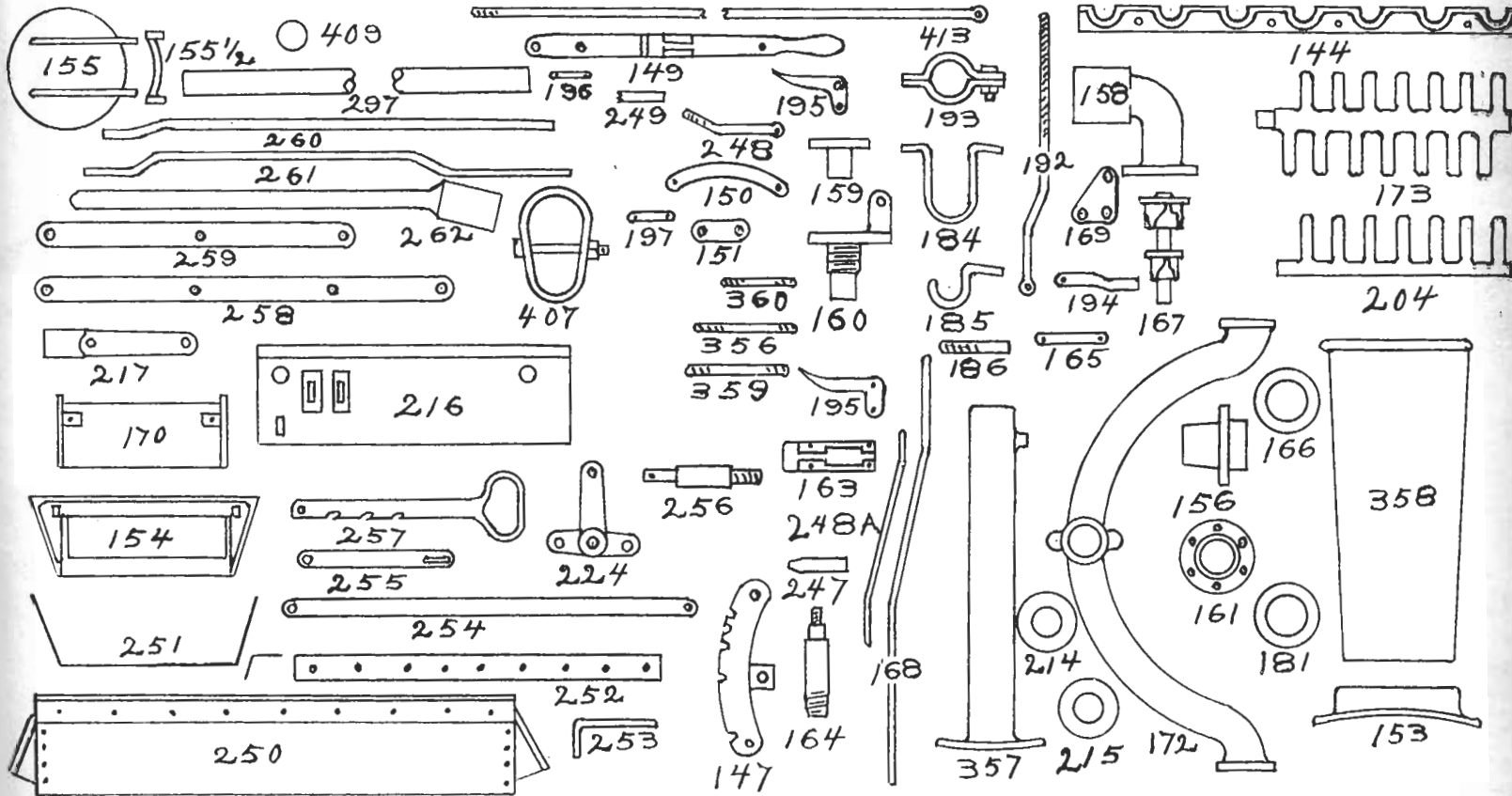



CUT No. 9—BOILER ACCESSORIES AND TRIMMINGS.

46-A	Long Drip Cock Lever (New Style)	381	Prismatic Water Column, without Fittings
221	Bracket for Pump Lubricator	382	Glass for Prismatic Water Column
222	Bell Crank for Pump Lubricator	383	Gasket for Prismatic Water Glass
222-A	Bell Crank for Pump Lubricator (New Style)	384	Pad for Prismatic Water Glass
223	Connections for Rod for Lubricator	385	Valve Fittings for Prismatic Water Column
225	Hill-McCanna Pump Lubricator, Single Feed	386	2-inch Angle Valve, Boiler to Engine
225-A	Hill-McCanna Pump Lubricator, Double Feed	387	1½-inch Gate Valve, Ejector to Tank
226	Stud for Lubricator Bell Crank	388	1-inch Globe Valve, Boiler to Ejector
227	Lubricator Sight Feed, complete	389	1-inch Corner Valve, Check to Boiler, R. H.
228	Lubricator Sight Feed Glass with Gaskets	390	1-inch Corner Valve, Check to Boiler, L. H.
229	Line Check for Oil Pump	391	1-inch Steam Cock between Tank and Inspirator
230	⅛-inch Copper Pipe for Oil Pump	392	1-inch Angle Blow-off Valve
363	Box for Oil Pump Rocker Stand	393	¾-inch Angle Valve, Boiler to Inspirator
364	Rocker Stand for Oil Pump	394	1-inch Check Valve, Inspirator to Corner Valve
365	Stud for Rocker Stand No. 364	395	½-inch Globe Valve for Blower, also for Steam Hose
366	Stud in No. 104 Oil Pump Drive	396	2-inch Pop or Safety Valve
367	Stud in No. 222, Large	397	Whistle
368	Stud in No. 222, Small	398	¾-inch Relief Valve in Cylinder
369	Connecting Rod between Nos. 104 and 364	399	¾-inch Fusible or Soft Plug
371	Collar 1⅛ in. for Nos. 372 and 373	406	2-inch Brass Pipe Plug
372	Shaft for No. 364	408	Special Tee from Injector to Boiler
373	Shaft for No. 46-A	162	Combination Valve
374	Connecting Rod between Nos. 364 and 222.	414	2-inch to 1-inch Reducing Bushing for Blow-off
375	Hancock Inspirator Type C-17½	418	Water Gauge Cocks
376	Ejector for Filling Tank	421	Strainer Valve for 1-inch Suction Pipe.
377	Steam Gauge	422	Strainer for Valve
378	Steam Gauge Syphon	423	¼-inch Air Cocks
379	Steam Gauge Bracket	298	Tank (Not Illustrated)
380	Prismatic Water Column with Fittings to Boiler, complete	299	Boiler (Not Illustrated)

CUT NO. 9

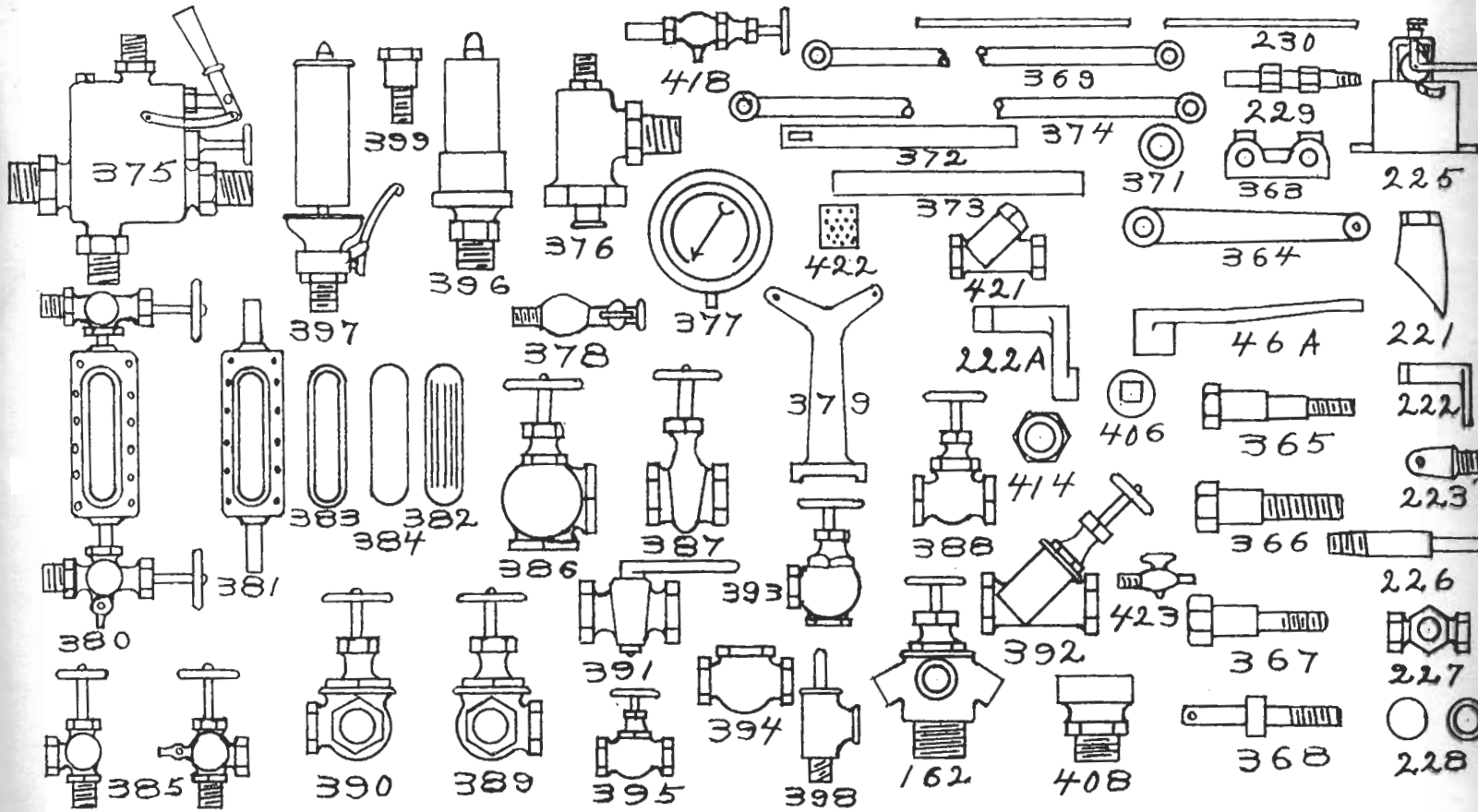

CUT No. 10-CAB PARTS, HOSE AND HEAD LIGHTS

279	Cab, complete (Not Illustrated)
280	Top, complete
281	Rear End
282	Front End
283	Side for Either Side
284	Door for Either Side
285	Window for Either Side
286	Curtain (Not shown)
287	Angle Iron Support for Cab
288	Hinges for Door
289	Catches for Door
290	Handle to Cab
291	Right Hand Step
292	Left Hand Step
293	Fuel Box
294	Angle Iron for Fuel Box
295	Brace for Fuel Box
296	Dome Cover
400	Suction Hose
401	Steam Hose
402	Gong
403	Headlight
404	Chimney 10½ in. for Headlight
405	Chimney 7½ in. for Headlight
430	Wicks
410	Curtain Rod
415	Strainer for Suction Hose

CUT NO. 10

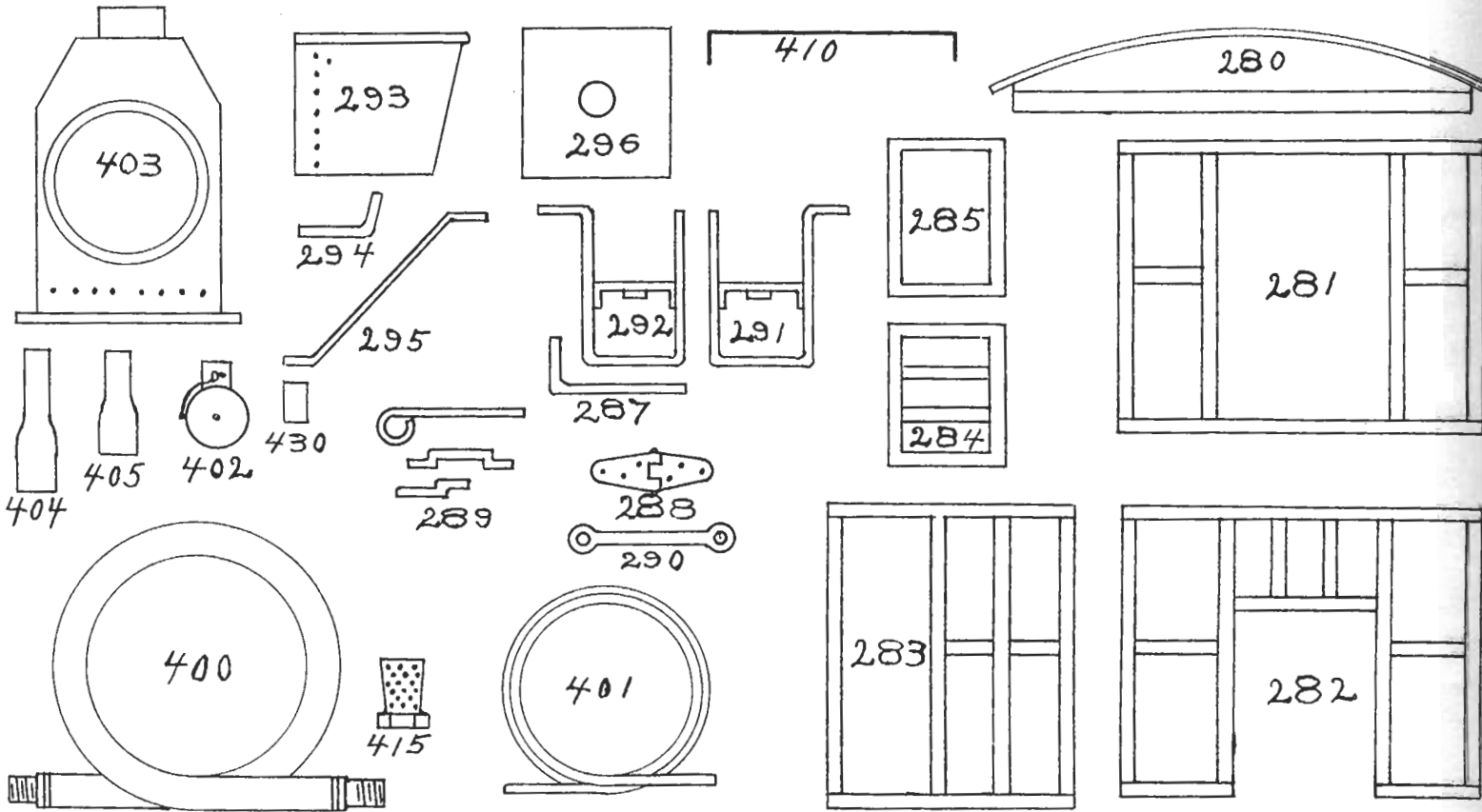

CUT No. 11—TOOLS AND PACKING

700	1/2-inch Single End Wrench
701	3/8-inch and 1/2-inch Double End Wrench
702	5/8-inch and 3/4-inch Double End Wrench
703	7/8-inch and 1-inch Double End Wrench
704	5/8-inch and 3/4-inch Double End Set Screw Wrench
705	1/2-inch Single End Set Screw Wrench
706	14-inch Stilson Pipe Wrench
707	24-inch Stilson Pipe Wrench
708	10-inch Wescott Wrench
709	12-inch Monkey Wrench
710	Eccentric Set Screw Wrench
711	5/8-inch Box Wrench
712	3/4-inch Box Wrench
713	Spanner Wrench for Valve Stem
714	8-inch Screw Driver
715	2-inch Ball Pein Hammer
716	Hand Oil Can
717	One Quart Long Stem Oil Can
718	Two Quart Short Stem Oil Can
719	Tube Expander
720	Tube Cleaner, plain
721	Tube Cleaner, with Brush
750	Piston Rod Packing
751	Slide Valve Rod Packing
752	Throttle Valve Rod Packing
753	Hand Valve Stem Packing
754	3/8-inch Square Spiral Packing for Exhaust Pipe
755	Asbestos Sheet Packing
756	Piston Rod Packing, 1 1/4 in. x 1 7/8 in., Type C.
757	Steam Chest Packing
758	Cylinder Head Packing

CUT NO. 11

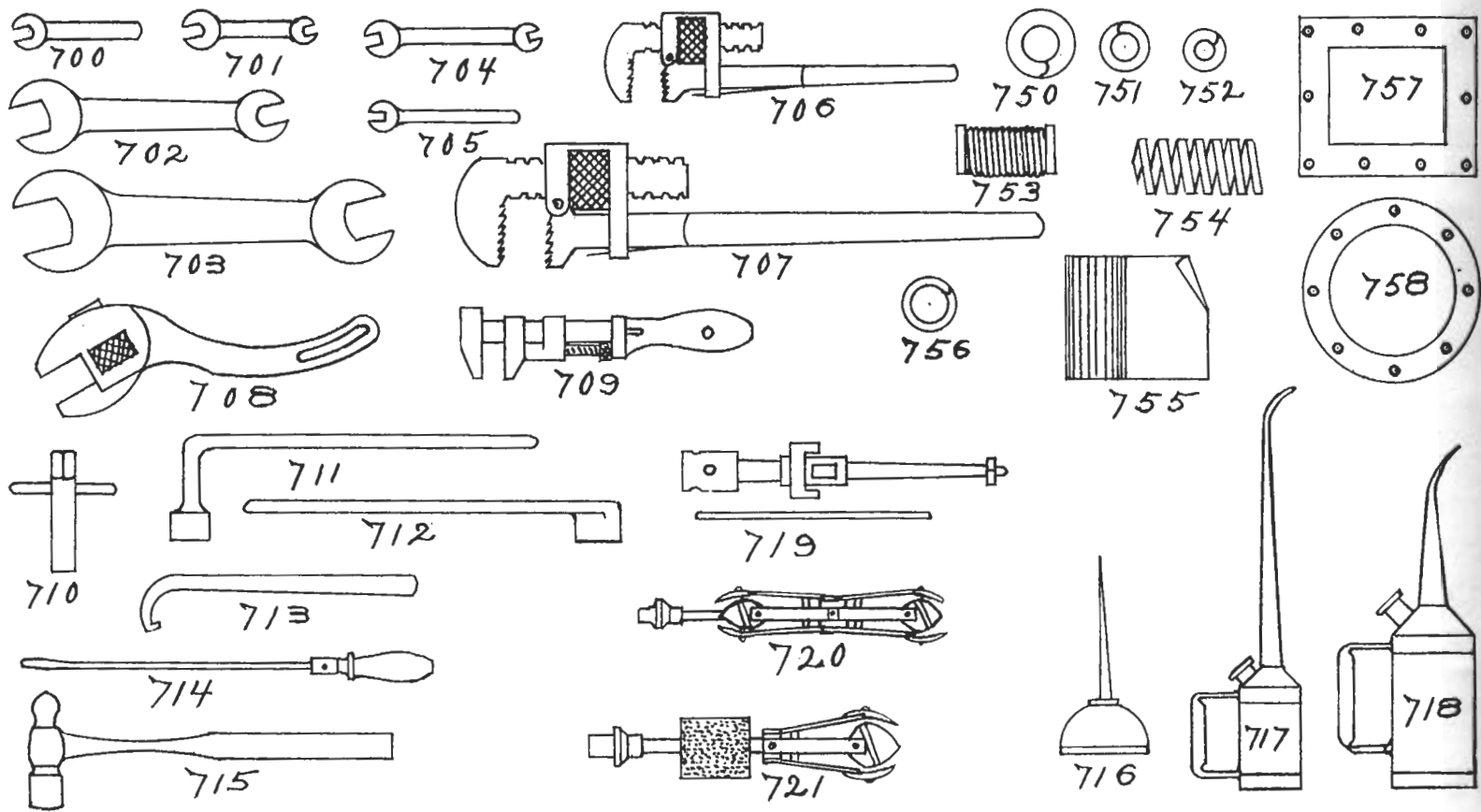

CUT No. 12—LOGGING SLEDS

600	Sleds, complete (Not illustrated)	618	Locking Pin with Chain, for holding Pin in Roller Irons
601	Sled Irons, with Bolts (Not illustrated)	619	Bar Irons
602	Sled Irons without Bolts (Not illustrated)	620	1-inch Pin with Chain for Bar Irons
603	Wood Bar or Bench	621	Rocker Plates
604	Wood Runner, 6-inch	622	Taper Head Pin with Rocker Plates
605	Wood for Malleable Roller Iron	623	2-inch Rocker Pin
606	Wood for Roller when Malleable Nose Iron is Used	624	Nose Iron Forging
607	Wood for Forward V-Pole	625	Nose Iron, Right Hand (Malleable)
608	Lombard Knee, complete, includes Nos. 609, 610, 611, 612 and 613	626	Nose Iron, Left Hand (Malleable)
609	Lombard Knee Casting (Malleable)	627	1¼-inch Tomkin, used with Malleable Nose Irons
610	Lombard Knee Side Plate	628	Ring for Roller, used with Malleable Nose Irons
611	Lombard Knee Top Plate	629	Reach Irons
612	1¼-inch Pin for Lombard Knee	631	Forward Pole or V-Iron, ¾ in. thick
613	½-inch Cotter for Lombard Knee	632	4-inch Shoe, special steel drilled and fitted
614	Roller Iron Right (Malleable)	633	2-inch Shoe or Keel Shoe, special steel drilled and fitted
615	Roller Iron Left (Malleable)	634	1-inch Pin for holding Reach in New Style Malleable Nose Iron
616	1½-inch Tomkin or Pin for Roller Iron		
617	1-inch Crooked Pin with Chain for Holding Reach Iron in Roller Chains		

CUT. NO. 12

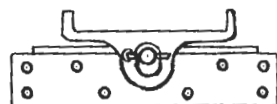
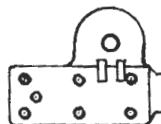
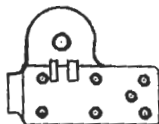
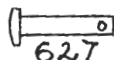
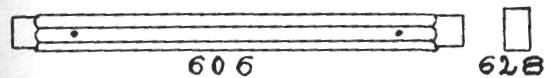
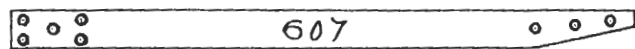
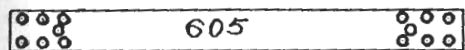
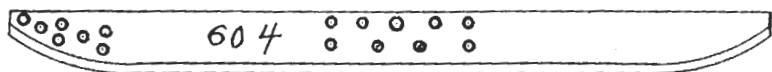
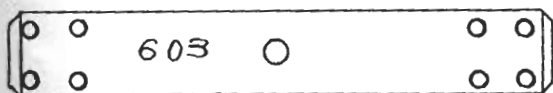

621

606

628

622

627

615

614

608

623

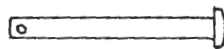
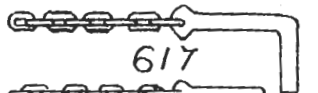

609

617

616

618

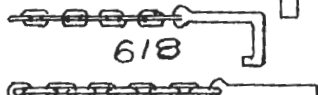

610

620

619

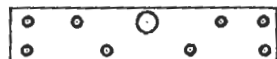
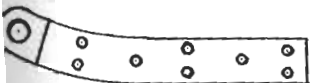

624

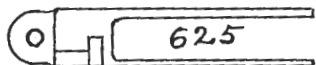
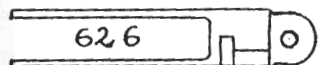

626

625

611

634

629

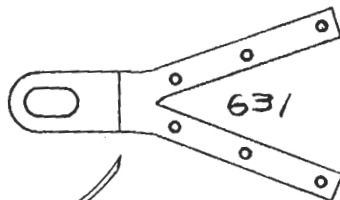

612

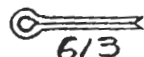

613

632

633





CUT No. 13—SNOW PLOW OR SCRAPER PARTS.

- 500 Snow Plow or Scraper, complete (Not illustrated)
- 500-A Sectional View of Snow Plow or Scraper
- 501 Snow Plow Knife or Cutter
- 502 Lifter Shaft
- 503 Lifter Shaft Hanger
- 504 Lifter Shaft Lever (extra heavy)
- 506 Lifter Shaft Lever
- 507 Lifter Shaft Chain
- 508 Worm Gear
- 509 Worm Gear Shaft
- 510 Hand Wheel
- 511 Hand Wheel Shaft
- 512 Worm
- 513 Sheave
- 514 Main Casting to Lifting Unit
- 515 Collar for Worm Gear Shaft
- 516 Coupling Iron
- 518 1-inch Coupling Pin with Chain
- 519 Check Chain
- 520 Brace

CUT NO. 13

